



Automated Motor Performance System AMPS - Data Sheet

STANDARDIZATION WITH AUTOMATED TEST SOLUTIONS

KEY FEATURES:

- **Customizable** to test several types of Auxiliary Power Unit (APU) Direct Current (DC) Starter Motors
- **Software-driven** capabilities to easily expand to additional motor types
- **Functional design** can be easily configured to use a variety of dynamometers and power supplies
- **Compact system** includes a stow-away keyboard and mouse

X Technologies' adaptation of a standard product provided the United States Air Force with a quick turn solution.



X Technologies, Inc. designed its XT3000 Automated Motor Performance System (AMPS) with easy operation and functionality in mind. Boasting a single-rack, functional design and customizable features that will meet every requirement and exceed expectations, this AMPS is the best of its breed. The AMPS is capable of testing several types of Auxiliary Power Unit (APU) Direct Current (DC) starter motors through the use of file-driven software that allows for additional starter motors to be added without the hassle of rewriting software. The capacity to add an array of starter motors to this one system is accomplished with the use of several initialization and support files for each motor. Currently, the software includes instructions for five starter motors with the further ability of having up to seven additional motors added without modifying the software.

Additionally, the AMPS consists of two DC power supplies, a hysteresis dynamometer, dynamometer controller, free-run speed sensor, industrial computer, touch screen monitor, and laser printer.

AMPS Software

The starter motor testing is controlled by an easy to use Test Program Sets (TPS). The XT3000 allows the operator to intervene using the touch screen, keyboard and mouse. Both the keyboard and mouse are conveniently located in a single rack mounted unit, which may be stowed when not in use. The computer is a rack mounted industrial unit with a Windows

XP Professional operating system with the AMPS Test Program (TPS) written in National Instruments LabVIEW.

New TPSs can be easily added through the use of pre-defined test files and routines.



Safe-To-Turn-On Test Screen

System Hardware - Instrument Cabinet

All instruments are installed in a 70-inch tall cabinet that houses the touch screen monitor, dynamometer controller, storage drawer, computer, keyboard and mouse, electrical interface panels, printer and DC power supplies.

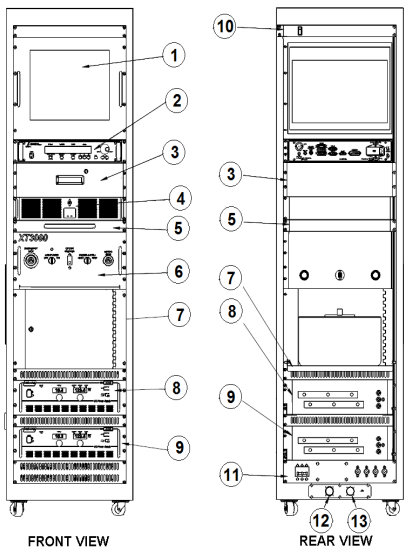

1. Industrial Image Touch Screen Monitor
2. Magtrol DSP6001 Dynamometer
3. Storage Drawer
4. Rack Mount Industrial Computer
5. Keyboard/Mouse Drawer
6. Electrical Control Panel
7. Printer Shelf and HP1006 Printer
8. Argantix 30-333 DC Power Supply 1
9. Argantix 30-333 DC Power Supply 2
10. Hammond Power Strip
11. High Voltage Panel
12. 480 VAC Power Connector
13. 120 VAC Power Connector

Safety Features

The XT3000 is designed with operator and motor safety in mind. Safety features include:

Scatter Shield-This is a 360-degree shield constructed of polycarbonate plastic to protect the operator from flying debris in the event of engine failure.

Emergency Button- When pressed, all power is instantaneously removed from the system.

Motor Stop Button- When pressed, the output from both power supplies is cut off. This may also be accomplished from the keyboard or a button located on the touch screen.

Door Closed Sensor- This sensor assures the scatter shield door is closed prior to testing a starter motor.

High Voltage Safety Shield- Located in the lower rear of the test system, this shield keeps personnel from inadvertently touching the high voltage and high current outputs.



100 Sandau, Suite 300
San Antonio, TX 78216
(210) 822-8712
(210) 822-8796 (fax)
www.x-technologies.com

System Hardware- Test Bench and Fixture

The test bench is comprised of the 80/20 aluminum bench, HD-800-6N-0200 dynamometer, free running speed sensor, scatter shield and air cooling panel. Power, ground, dynamometer control cables and digital signals are provided from the instrument cabinet. The area underneath the dynamometer may be used for storage or future expansion of the AMPS.

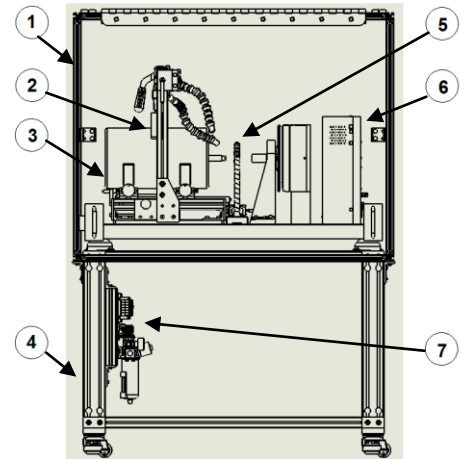

1. Custom Scatter Shield
2. Magtrol AMF-V Motor Fixture
3. Motor Under Test
4. Magtrol TAB 0800L Test Bench
5. Magtrol FR10 Free Running Speed Sensor
6. Magtrol HD-800-6N-0200 Dynamometer
7. Custom Cooling Air Panel

Test Specifications:

Safe-to-Turn-On Test

Power Supply Setting	3.8
Test Requirements	Test Limits
Min Current (amps)	25
Max Current (amps)	55
Motor Direction	CCW

No-Load Test

Power Supply Setting (volts)	22
Torque Setting (oz-in)	0
Test Requirements	Test Limits
Max Current (amps)	55
Speed Range (rpm)	18000-20000
Motor Direction	CCW

Rated-Load Test

Power Supply Setting (volts)	16
Torque Setting (oz-in.)	299.8
Test Requirements	Test Limits
Max Current (amps)	145
Min Speed (rpm)	4500-5500